



solar never looked so good

# solar for housing



Matching Clearline heating and PV panels enable the harmonious use of both solar technologies on the same roof.

Will it complement the appearance of the house?



Choice of sizes offers flexibility to build up the panel area in the most appealing way, while avoiding other roof features.



Free design service provides advice to energy assessors, energy reports to discharge planning conditions and roof layout plans and elevations.

How can we meet our energy targets in the most efficient way?



Sleek and thin, Clearline solar panels finish low in the roofline for a stunning aesthetic.

“I never thought solar could be so simple.”  
Gary Blake, Site Manager,  
Mansell Construction

“Approachable, with the best technical knowledge I've come across.”  
Alex Bakes, Estimator,  
Southdale Ltd.

“Your service has been first class, no issues, only praise.”  
Grant Milward, Contracts Manager,  
Fairley Brown and Co Ltd.



How will it fit into the build programme?

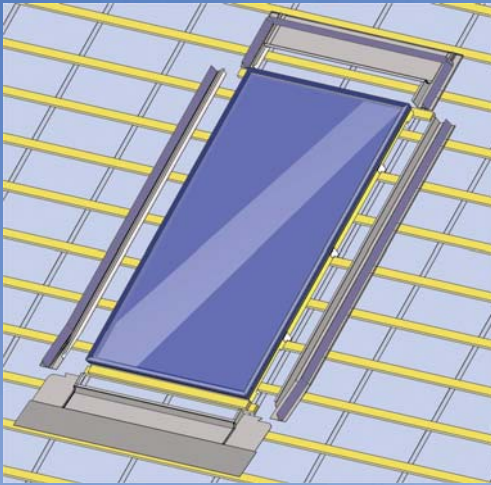

Patented roof-integration details, with no plumbing or electrical connections to make outside the building, allow rapid installation by a roofing contractor. Kits are available for both slate and tile roofs.

Will it be durable?



Viridian manufactures and supplies the whole solar installation kit. Clearline panels have been tested as a building element as well as for energy performance and were first to achieve BBA certification for roofing durability.



Clearline solar panels are lighter than the tiles they replace, removing the need for structural work in retrofit situations.

Will it be easy to maintain?

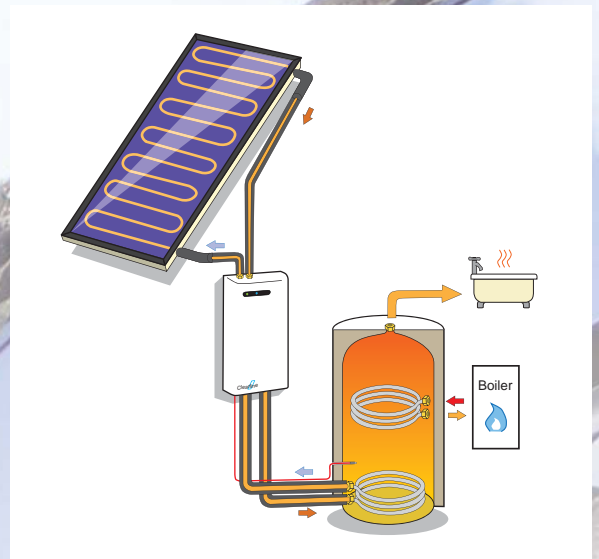

Simple plumbing systems are available for solar heating, including drain-back for robustness and ease of maintenance.

Does the roof need strengthening?

we've got the answers



# solar for larger buildings



Extracare units, hotels, sports and medical buildings generally have a centralised plant room, so a solar heating system can pre-heat water in large buffer vessels.

Is solar heating an option?



Panels can be installed on flat roofs at different pitch angles to optimise energy yield per unit area of roof, energy yield per solar panel, or to take account of planning restrictions on the height of the roof.

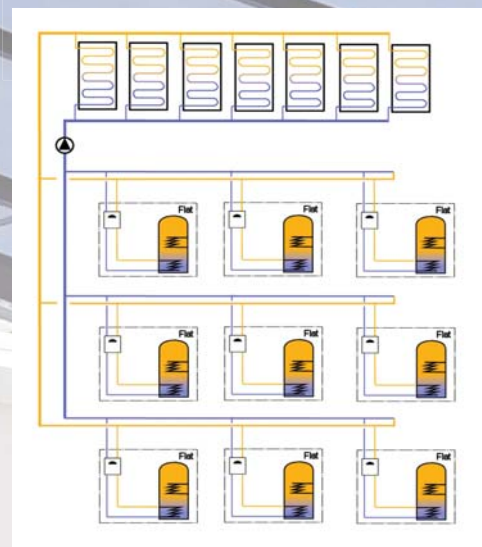

The Cirrus communal solar heating system, exclusive to Viridian Solar, opens up the possibility of providing solar water heating to high rise apartment blocks without the need for a communal plant room.

Can we keep within a height restriction?

“An innovative product that’s helped us hugely over the years.”  
Paul Fassnidge,  
Senior Energy Consultant  
Willmott Dixon ReThinking

“Your quick response really helped us.”  
Helen Fairmaner, Architect,  
Jane Darbyshire and David  
Kendall Ltd.

“You engage with our design team to find the best solution.”  
Warren Sparkes,  
Sustainability Manager,  
Hill Partnerships



How do we ensure the roof is weathertight?



Viridian has a range of robust standard details for fixing panels against wind loads for a wide variety of flat roof build-ups



Can we use both PV and solar heating?



Clearline heating and PV panels come in a range of identical sizes and use the same fixing details so they can be mixed and matched.



Viridian's design team can guide you through the process of selecting which solar technology is best for your building and optimising the roof layout, taking into account access requirements and other plant and equipment.

How much solar will fit on the roof?

you've come to the right place



## Clearline<sup>®</sup> PV

High performance monocrystalline silicon photovoltaic panels for pitched roof integration or flat roof mounting.

---



## Clearline<sup>®</sup>

High performance solar heating panels for pitched roof integration or flat roof mounting.

---



## cirrus<sup>™</sup>

Communal solar hot water system for tall buildings.

---



## Symphony<sup>™</sup>

Solar optimised twin coil hot water cylinders.

---



## SolarSure<sup>™</sup>

Solar installation accreditation service.

---



## Clearline<sup>®</sup> Aura

Wireless colour touch-screen solar energy display.

---



# about us

Viridian Solar aims to encourage the widespread adoption of solar energy in mainstream building practice.

A team of engineers and designers set themselves the challenge to design a cost-effective solar water heater. Realising that a critical proportion of the cost of solar panels is the way that they are fitted, Viridian sought partners from the building industry to help with the definition and specification of the product. The result of this collaboration with developers, construction companies and other building professionals was a product that transforms the attractiveness and ease of installation of this type of renewable energy.

The story of innovation has continued with the introduction of a photovoltaic solar panel, solar hot water cylinder and solar energy display. All have been developed with guidance from construction industry partners.



Viridian Solar  
Atlas Building, 68 Stirling Way  
Papworth, Cambridge.  
CB23 3GY

Tel 01480 831 501  
enquiries@viridiansolar.co.uk

[www.viridiansolar.co.uk](http://www.viridiansolar.co.uk)